



HAND MIXER & BLENDER COMBO MB-21

Professional hand blender and beater. 300 W.



is connected to the mains.

Built to last

- ✓ Professional performance: capable of carrying out prolonged work without the casing overheating.
- ✓ Life-plus: equipped with a motor which has passed all of the most demanding usage tests.
- ✓ Studied geometry: casing designed to avoid rolling and falling.
- ✓ Easy to clean: detachable arms, can be cleaned under the tap.
- ✓ Approved by NSF: guaranteed safety and hygiene.

INCLUDES

- ✓ Variable speed motor block.
- ✓ MA-21 mixer arm.
- ✓ Whisk BA-20.
- ✓ Wall mount.

ACCESSORIES

- Mixer arms MA-20
- Whisk BA-20

SPECIFICATIONS

Total loading: 300 W

Plug: --

Liquidiser function

Maximum recipient capacity: 12 l
 Maximum working depth: 169 mm
 Motor speed: 1500 - 15000 rpm
 Blade diameter: 50 mm
 Blade guard diameter: 82 mm
 Liquidising arm length: 250 mm
 Total length: 514 mm

Whisk function

Motor speed: 200 - 800 rpm
 Capacity (egg whites): 2 - 30
 Revolving arm length: 306 mm
 Total length (with revolving arm): 570 mm
 Net weight: 3.2 Kg

Noise level (1m.): <80 dB(A)

Crated dimensions

440 x 375 x 105 mm
 Gross weight: 3.8 Kg

AVAILABLE MODELS

3030634 Immersion blender & whisk combo MB-21 230/50-60/1

3030760 Combined MB-21 230/50-60/1

* Ask for special versions availability

SALES DESCRIPTION

- ✓ Variable speed motor block.
- ✓ 250 mm detachable mixer arm designed for continuous use in recipients of up to 12 l.
- ✓ Whisk with capacity for 2 to 30 egg whites.

All-in-one

- ✓ Professional hand blender and beater.
- ✓ Professional hand blender designed for carrying out different preparations without the need for add-on tools.
- ✓ Professional Y-blade, made from tempered steel and with a long-duration cutting edge.
- ✓ Vario-speed: variable speed.
- ✓ Mixer arm designed to work in recipients of up to 12 litres.
- ✓ Beater with capacity for 2 to 30 egg whites.

Maximum comfort for the user

- ✓ Compact design: logical and manageable size.
- ✓ Ergo-design & bi-mat-grip: external casing made in two materials for an ergonomic hold. Anti-slip grip. Optimum inclination of handle, minimising fatigue.
- ✓ Click-on-arm: detachable arm with fast and secure closure.
- ✓ Mixer arm hood designed to avoid splashes.
- ✓ Intuitive use: very simple operation. Warning light when the machine



www.sammic.co.uk

Food Service Equipment Manufacturer

Unit 2, Trevanth Road
 Troon Industrial Park
 LE4 9LS - Leicester

uksales@sammic.com
 Tel.: +44 0116 246 1900



Project

Date

Item

Qty

Approved

DYNAMIC PREPARATION
COMMERCIAL HAND BLENDERS

product sheet
updated 26/01/2022



HAND MIXER & BLENDER COMBO MB-21

Professional hand blender and beater. 300 W.



DYNAMIC PREPARATION
COMMERCIAL HAND BLENDERS

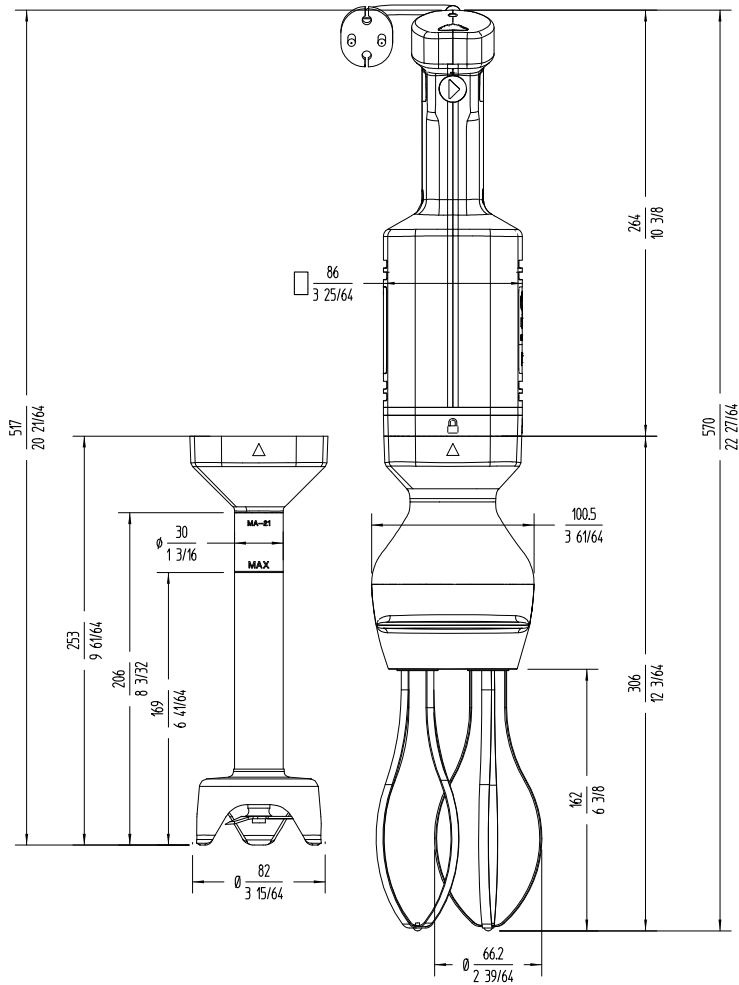

www.sammic.co.uk

Food Service Equipment Manufacturer

Unit 2, Trevanah Road
Troon Industrial Park
LE4 9LS - Leicester

uksales@sammic.com
Tel.: +44 0116 246 1900



Project

Date

Item

Qty

Approved

product sheet
updated 26/01/2022